

20 YEARS OF LEPTIN

Connecting leptin signaling to biological function

Margaret B Allison and Martin G Myers Jr

Departments of Internal Medicine, and Molecular and Integrative Physiology, University of Michigan, 1000 Wall Street, 6317 Brehm Tower, Ann Arbor, Michigan 48105, USA

Correspondence should be addressed to M G Myers
Email
mgmyers@umich.edu

Abstract

Hypothalamic leptin action promotes negative energy balance and modulates glucose homeostasis, as well as serving as a permissive signal to the neuroendocrine axes that control growth and reproduction. Since the initial discovery of leptin 20 years ago, we have learned a great deal about the molecular mechanisms of leptin action. An important aspect of this has been the dissection of the cellular mechanisms of leptin signaling, and how specific leptin signals influence physiology. Leptin acts via the long form of the leptin receptor LepRb. LepRb activation and subsequent tyrosine phosphorylation recruits and activates multiple signaling pathways, including STAT transcription factors, SHP2 and ERK signaling, the IRS-protein/PI3Kinase pathway, and SH2B1. Each of these pathways controls specific aspects of leptin action and physiology. Important inhibitory pathways mediated by suppressor of cytokine signaling proteins and protein tyrosine phosphatases also limit physiologic leptin action. This review summarizes the signaling pathways engaged by LepRb and their effects on energy balance, glucose homeostasis, and reproduction. Particular emphasis is given to the multiple mouse models that have been used to elucidate these functions *in vivo*.

Key Words

- ▶ leptin
- ▶ signal transduction
- ▶ obesity
- ▶ hypothalamus

Journal of Endocrinology
(2014) 223, T25–T35

Introduction

Obesity and its many comorbidities present a significant challenge to public health in the USA. The health care costs associated with obesity totaled more than \$147 billion annually. In addition to the economic burden, obesity results in premature death and disability from stroke, cardiovascular disease, and type 2 diabetes mellitus (<http://www.cdc.gov/obesity/data/adult.html> accessed 6/29/14). Furthermore, the obesity epidemic is no longer confined to the USA. Worldwide, more than 1.4 billion adults were overweight or obese in 2008 (Danaei *et al.* 2011). Clearly, the need for anti-obesity therapies is large and growing larger, yet no pharmacotherapies have been achieved more than minimal success in promoting long-term weight loss.

At its most basic level, body weight is determined by the amount of energy taken in relative to energy expenditure (Schwartz *et al.* 2000). If energy intake exceeds energy expenditure, excess energy accumulates in the form of triglycerides stored in adipose tissue, resulting in weight gain and obesity. However, the brain integrates signals of long-term energy stores with other physiologic inputs to modulate energy intake relative to energy expenditure. When adipose energy (fat) stores fall, hunger increases and energy expenditure decreases to defend body energy stores; conversely, the brain responds to nutritional surfeit by permitting increased energy expenditure and decreased feeding to maintain a constant body weight.

One of the most important and widely studied players in the control of energy balance is the hormone leptin (Friedman & Halaas 1998, Elmquist *et al.* 2005). Leptin was discovered by Zhang *et al.* (1994). Defects in leptin production underlie the massive obesity observed in *ob/ob* mice. Leptin is produced in adipose tissue in proportion to triglyceride stores, and serves as a critical indicator of an organism's long-term energy status (Frederich *et al.* 1995a, Maffei *et al.* 1995). Leptin acts primarily in the brain, especially the hypothalamus, where its action is integrated with that of other adipokines, gastrokines, and other signals to coordinate energy homeostasis (Friedman & Halaas 1998, Bates & Myers 2003, Myers *et al.* 2009, Ring & Zeltser 2010). In addition to leptin-deficient *ob/ob* mice, rare human mutations resulting in leptin deficiency have also been identified; leptin-deficient mice and humans display hyperphagia, decreased energy expenditure, and early-onset obesity (Montague *et al.* 1997, Farooqi *et al.* 1999). Leptin receptor (LepRb)-deficient humans and *db/db* mice display a similar phenotype (Tartaglia *et al.* 1995, Chua *et al.* 1996). Numerous studies have elaborated the critical role of leptin in the modulation of energy balance: the lack of leptin, as in starvation or genetic leptin deficiency, increases hunger while promoting an energy-sparing program of neuroendocrine and autonomic changes, including decreased sympathetic nervous system

tone, thyroid function, growth, and reproduction (Ahima *et al.* 1997). Leptin treatment largely reverses these changes (Farooqi *et al.* 1999, 2002). Decreased leptin also promotes a variety of other behavioral and physiologic changes to respond appropriately to low energy stores (Lu *et al.* 2006, Liu *et al.* 2010, 2011).

Despite the initial heralding of leptin as a potential cure for human obesity, most obese humans exhibit high circulating leptin concentrations (Maffei *et al.* 1995). Serum leptin increases in proportion to body fat percentage; obese patients secrete leptin at levels appropriate for their increased adipose mass and display elevated leptin concentrations ('hyperleptinemia') relative to lean controls (Tobe *et al.* 1999). Clearly, however, these high circulating leptin levels do not suffice to restore body adiposity to lean levels, as might be predicted based on the sensitivity of organisms to decreases in leptin signaling. Whether this inability of leptin to suppress feeding in the face of obesity results from an intrinsic or acquired defect in leptin action, or rather simply reflects the inability of homeostatic controls to overcome hedonic feeding drives remains a matter of debate. This controversy serves to underscore the importance of developing a more complete understanding of leptin signaling, its cellular effects, target neural pathways, and integration with other determinants of energy homeostasis (Figs 1 and 2).

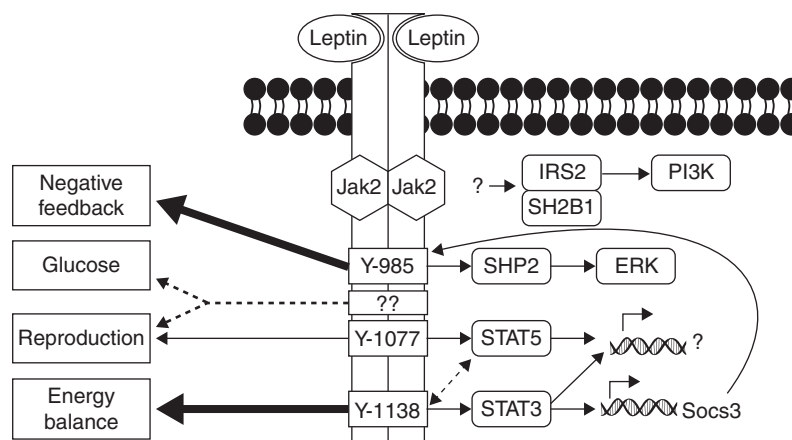
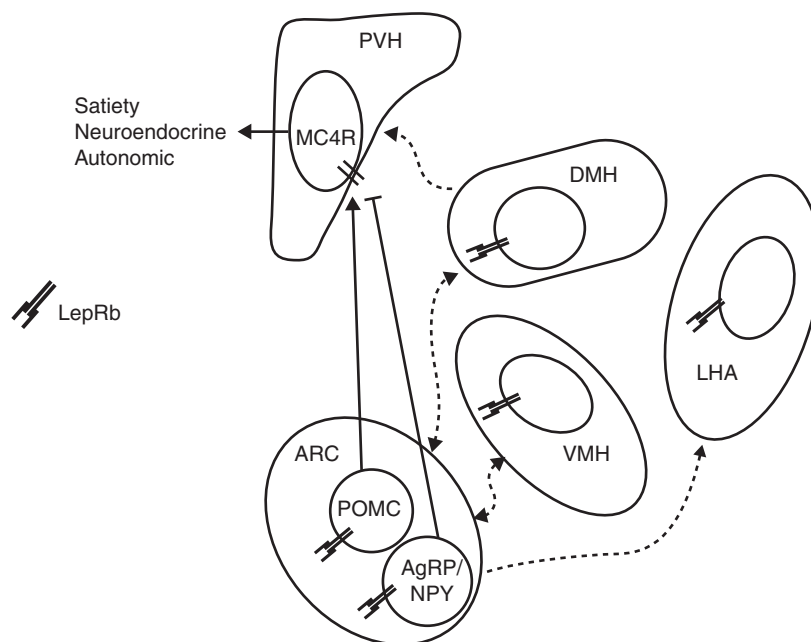

Figure 1

Leptin signaling and biological function. Leptin binds to LepRb, activating the associated JAK2 tyrosine kinase. Activated JAK2 phosphorylates the intracellular tail of LepRb on three tyrosine residues. Phosphorylated Tyr₉₈₅ recruits SHP2, which participates in ERK signaling; Tyr₉₈₅ also serves as a binding site for the negative feedback regulator, SOCS3. Phosphorylated Tyr₁₀₇₇ partially mediates leptin's control of reproduction; while STAT5 binds this site, STAT5 does not appear to participate in this effect of leptin. Phosphorylated Tyr₁₁₃₈ engages the STAT3 transcription factor.

LepRb → STAT3 signaling represents the primary mechanism by which leptin regulates energy balance, although the target genes of STAT3 in LepRb neurons remain undiscovered. Leptin also recruits the IRS2 → PI3K and SH2B1 pathways, although the mechanism of their recruitment to LepRb remains unclear. Some glucoregulatory and reproductive actions of LepRb appear to be mediated by unknown signals that function independently of LepRb tyrosine phosphorylation sites.

**Figure 2**

Hypothalamic leptin action. Leptin acts on its receptor (LepRb) on neurons in a series of interconnected hypothalamic nuclei to regulate satiety, neuroendocrine function, and autonomic tone. In the arcuate nucleus, leptin controls the melanocortin system through its opposing actions on POMC and AgRP neurons. ARC, arcuate nucleus; VMH, ventromedial

hypothalamic nucleus; DMH, dorsomedial hypothalamic nucleus; LHA, lateral hypothalamic area; PVH, paraventricular hypothalamic nucleus; MC4R, melanocortin 4 receptor; POMC, pro-opiomelanocortin; AgRP, agouti-related peptide.

Leptin and the LepRb

Leptin is a 146 amino acid protein produced in white adipose tissue in proportion to triglyceride stores (Frederich *et al.* 1995b). Once secreted into the circulation, leptin travels to the brain, where it enters the CNS, presumably via the choroid plexus and circumventricular organs. In the brain, leptin acts by binding and activating the long form of LepRb, which is expressed primarily on specialized subsets of neurons in certain hypothalamic and brainstem nuclei (Tartaglia 1997, Elias *et al.* 2000, Scott *et al.* 2009, Patterson *et al.* 2011). Mutations that inactivate LepRb, as well as antagonists of LepRb activation, confirm that leptin binding to LepRb is required for its biological activity (Chen *et al.* 1996, Shpilman *et al.* 2011). While the *LEPR* gene encodes multiple isoforms (LepRa-f in rats), only LepRb contains the full intracellular domain necessary for the activation of critical second messenger pathways and normal leptin action (Chua *et al.* 1996, 1997, Lee *et al.* 1996, Tartaglia 1997). Many functions for the other ('short') forms of the receptor have been hypothesized, including actions as a serum-binding protein that functions in leptin stabilization

or sequestration (Zastrow *et al.* 2003, Yang *et al.* 2004, Zhang & Scarpace 2009), or as a leptin transporter (Bjorbaek *et al.* 1998a, Kastin *et al.* 1999), but LepRb alone suffices for the control of energy balance, glucose homeostasis, and other leptin effects, and LepRb thus constitutes the focus of this review.

Peripheral actions of leptin

Multiple studies have attempted to assess the role of leptin in the periphery. Mice with ablated hepatic leptin signaling had normal body weight and blood glucose levels, but were protected from high-fat diet or age-induced insulin intolerance. Mice in which LepRb was deleted from the pancreas using a *Pdx^{cre}* or *Rip^{cre}* also showed improvements in glucose tolerance (Morioka *et al.* 2007, Huynh *et al.* 2010). However, interpretation of these results is confounded by hypothalamic CRE expression in both the *PDx* and *RIP* models (Schwartz *et al.* 2010, Wicksteed *et al.* 2010). LepRb expression has also been demonstrated in perivascular intestinal cells, although the function of LepRb in these cells has not been determined

(Rajala *et al.* 2014). Studies examining the role of LepRb in the heart have been difficult to perform based on the negative effects of *cre* expression on cardiac function (Hall *et al.* 2011). One model revealed an additive role for cardiac-specific LepRb deletion in inducing cardiac failure, however, suggesting that LepRb may regulate the cardiovascular system through both central and peripheral mechanisms (Hall *et al.* 2012).

Central actions of leptin

Within the brain, leptin acts on multiple populations of LepRb neurons – primarily in the hypothalamus and brainstem (Scott *et al.* 2009, Patterson *et al.* 2011). While leptin action in the nucleus of the solitary tract plays a role in the modulation of satiety, and ventral tegmental area LepRb contributes to the control of reward and aversion, hypothalamic LepRb appears to mediate the lion's share of leptin action on energy balance (Hommel *et al.* 2006, Hayes *et al.* 2010, Ring & Zeltser 2010). Within the hypothalamus, leptin acts on multiple populations of LepRb-expressing neurons, including those in the lateral hypothalamic area and the ventromedial, dorsomedial, ventral premammillary, and arcuate (ARC) nuclei (Scott *et al.* 2009, Patterson *et al.* 2011). Each of these sites contains multiple distinct types of LepRb cells, each of which contributes uniquely to leptin action. The most studied site of leptin action is the ARC, where leptin inhibits orexigenic agouti-related protein/neuropeptide Y-containing (AgRP/NPY) neurons and stimulates anorexigenic proopiomelanocortin (POMC)-containing neurons. POMC neurons produce anorexigenic neuropeptides, while AgRP is a potent antagonist of the melanocortin system and NPY mediates additional orexigenic signals (Schwartz *et al.* 2000).

LepRb signaling

LepRb is an IL6-type class I cytokine receptor, consisting of an extracellular leptin-binding domain, a single-pass membrane spanning domain, and an intracellular tail that contains binding domains for multiple signaling proteins (Tartaglia *et al.* 1995, Baumann *et al.* 1996). LepRb is present on the cell membrane as a mixture of monomers and dimers (Devos *et al.* 1997). Unlike many other cytokine receptors, ligand binding does not appear to activate LepRb by promoting receptor dimerization, but rather promotes a conformational change that results in the autophosphorylation and activation of JAK2, which is constitutively bound to Box1 and Box2 motifs in the

membrane-proximal portion of LepRb (Banks *et al.* 2000, Kloek *et al.* 2002). Activated JAK2 phosphorylates LepRb on three tyrosine residues in mice: Tyr₉₈₅, Tyr₁₀₇₇, and Tyr₁₁₃₈ (Banks *et al.* 2000, Gong *et al.* 2007). Each of these phosphorylated tyrosine (pY) residues represents a Src homology 2 (SH2)-binding motif that recruits specific SH2-containing effector proteins to the receptor to mediate subsequent signaling.

Leptin binding to LepRb results in the activation of several major signaling pathways. Importantly, phosphorylation of Tyr₁₁₃₈ results in the recruitment of STAT3 to LepRb, to permit its phosphorylation (pSTAT3) and activation by JAK2 (White *et al.* 1997, Banks *et al.* 2000). Activated pSTAT3 translocates to the nucleus, where it mediates changes in the expression of target genes, including suppressor of cytokine signaling 3 (*Socs3*) (which encodes a feedback inhibitor of LepRb signaling) (Bjorbaek *et al.* 1999). Phosphorylation of Tyr₉₈₅ recruits protein tyrosine phosphatase 2 (SHP2; PTPN1) to LepRb, contributing to the activation of the ERK signaling pathway (Banks *et al.* 2000, Bjorbaek *et al.* 2001). Tyr₉₈₅ also serves as the binding site for SOCS3 and thus plays a prominent role in the feedback inhibition of LepRb (Bjorbaek *et al.* 2000). Phosphorylated Tyr₁₀₇₇ promotes the recruitment and activation of STAT5; Tyr₁₁₃₈ may also contribute to STAT5 activation (Gong *et al.* 2007).

Another SH2 domain protein, SH2B1, also participates in LepRb signaling. In addition to increasing the amplitude of LepRb signaling via JAK2, SH2B1 may control specific downstream LepRb signals, including insulin receptor substrate (IRS)-proteins (Duan *et al.* 2004, Ren *et al.* 2005). IRS-proteins also participate in leptin action; they control the phosphatidylinositol 3-kinase (PI3K) pathway, and the subsequent regulation of Akt→FoxO1 and mTORC1 signaling (Niswender *et al.* 2001, Kim *et al.* 2006, Kitamura *et al.* 2006). The mechanism(s) whereby LepRb modulates this pathway remains obscure; some data suggest a potential role for poorly understood LepRb signaling that occurs independently of LepRb pY sites.

LepRb signaling and physiology

LepRb→STAT3 signaling

Multiple LepRb signaling pathways coordinate the regulation of energy homeostasis. Of these, the Tyr₁₁₃₈→pSTAT3 pathway plays an especially prominent role (Bates & Myers 2003). Mice containing a substitution mutation of LepRb Tyr₁₁₃₈ (which renders LepRb incapable of recruiting and activating STAT3; *s/s* mice) display

hyperphagia and obesity approaching that of *db/db* animals (although linear growth, fertility, and glucose homeostasis are relatively protected in *s/s* relative to *db/db* mice) (Bates *et al.* 2003, 2004, 2005). Furthermore, brain-specific STAT3-knockout mice (STAT3^{N-/-}) exhibit severe obesity (Gao *et al.* 2004). Mice in which STAT3 was deleted specifically in LepRb neurons (LepRb^{STAT3-KO}) similarly develop hyperphagic obesity with some preservation of glucose homeostasis (Piper *et al.* 2007). These studies highlight the importance of LepRb Tyr₁₁₃₈→STAT3 signaling for the regulation of body weight, but suggest some regulation of growth, reproduction, and glucose homeostasis by leptin independently of this pathway.

The role of STAT3 signaling in energy balance in discrete neural populations has been best characterized in the ARC. As might be expected, specific deletion of STAT3 from AgRP neurons results in moderate obesity, increased *Npy* expression, and decreased sensitivity to leptin (Gong *et al.* 2008). STAT3 deletion from POMC neurons also increases adiposity, but the effect is milder than that observed for the AgRP-specific knockout, suggesting a greater role for STAT3 in leptin action in AgRP neurons than in POMC cells (Xu *et al.* 2007). In contrast to STAT3 deletion studies, the interpretation of studies in which a mutant, transcriptionally active, form of STAT3 (STAT3-C) is expressed in ARC neurons is more complicated. While STAT3-C expression in AgRP neurons promotes leanness, STAT3-C expression in POMC neurons results in obesity (Mesaros *et al.* 2008, Ernst *et al.* 2009). *Agrp* expression is not altered in *Agrp*^{STAT3-C} mice, consistent with the notion that *Agrp* expression is more sensitive to modulation by PI3K than by STAT3 (see below) (Mesaros *et al.* 2008). It is possible that the mild obesity resulting from STAT3-C action in POMC neurons results from altered transcriptional activity of this isoform relative to native STAT3, but STAT3-C also promotes *Socs3* expression, which could limit endogenous leptin action despite increased transcription mediated by STAT3-C. Interestingly, although the *Pomc* promoter contains known STAT3-binding sites (Munzberg *et al.* 2003) and *Pomc* expression is decreased in *s/s* mice and animals with neuronal STAT3 ablation (Bates *et al.* 2003, Gao *et al.* 2004), *Pomc* expression is decreased in *Pomc*^{STAT3-C} animals (Ernst *et al.* 2009), suggesting that while *Socs3* represents a direct STAT3 target, the control of ARC *Pomc* expression may reflect the effects of additional and/or downstream LepRb signals, as well. Additionally, none of the phenotypes resulting from the modulation of LepRb→STAT3 signaling in POMC or AgRP neurons approach that of brain or hypothalamus-wide modulation, suggesting that LepRb→STAT3 signaling in other,

non-ARC LepRb cells contributes to the control of energy balance during LepRb→STAT3 signaling.

Tyr₉₈₅-dependent signaling, SOCS3, and SHP2

In contrast to the obese phenotype that results from disruption of LepRb→STAT3 signaling, mice with a mutation in Tyr₉₈₅ display a lean phenotype (which is especially pronounced in females). These mice also display decreased hypothalamic *Agrp* expression, increased pSTAT3, exaggerated sensitivity to exogenous leptin, and resistance to DIO (Bjornholm *et al.* 2007). These results are consistent with increased LepRb signaling due to decreased LepRb feedback inhibition via disruption of SOCS3 binding. Indeed, as for mice mutant for LepRb Tyr₉₈₅, disruption of *Socs3* in the brain decreases adiposity (more dramatically in female than in male mice) and increases the response to exogenous leptin (Mori *et al.* 2004).

In addition to its role in feedback inhibition, Tyr₉₈₅ may also coordinate energy homeostasis via SHP2/ERK signaling (Bjorbaek *et al.* 2000, 2001). As a tyrosine phosphatase, SHP2 was initially investigated as a potential negative regulator of leptin signaling. However, deletion of *Shp2* from the forebrain disrupts ERK signaling and promotes early-onset obesity (Zhang *et al.* 2004). Furthermore, deletion of *Shp2* from POMC neurons results in mild obesity and increased susceptibility to DIO (Banno *et al.* 2010). Similarly, female mice expressing a dominant active SHP2 mutant in the brain are resistant to DIO (He *et al.* 2012). Thus, these data are consistent with the notion that LepRb→SHP2 signaling is important for leptin action and the control of energy homeostasis, rather than SHP2-mediated feedback inhibition on LepRb. While SHP2 plays an essential role in the control of energy homeostasis, however, the promiscuity of SHP2 (which plays roles in many signaling pathways) renders it difficult to assess the specificity of SHP2 effects for LepRb signaling.

Tyr₁₀₇₇ and STAT5

LepRb→STAT5 signaling appears to have little impact on energy balance. While brain-wide STAT5 knockout mice develop late-onset obesity, this phenotype is quite mild (Lee *et al.* 2008). LepRb Tyr₁₀₇₇ mutants develop only mildly increased food intake and adiposity (Patterson *et al.* 2012). Furthermore, a recent study deleting STAT5 specifically in LepRb neurons has revealed no body weight phenotype; deleting both STAT3 and STAT5 that did not produce a more robust phenotype than deleting STAT3 alone (Singireddy *et al.* 2013). Also, Tyr₁₀₇₇ mutants enter

puberty normally, but have a prolonged inter-estrus interval, suggesting mild subfertility in these animals. However, LepR^{STAT5-KO} animals display normal estrus cycling and fertility. Altogether, these studies suggest that Tyr₁₀₇₇ plays a minor role in the control of feeding and reproductive functions, but that STAT5 may not be the binding partner that mediates this effect.

Other LepRb signals

Although the tyrosine phosphorylation of LepRb is essential for the majority of leptin's actions, mice in which Tyr₉₈₅, Tyr₁₀₇₇, and Tyr₁₁₃₈ have all been replaced with phenylalanine (LepRb^{3F}) are less slightly less obese than *db/db* animals and display significant improvements in glucose homeostasis and fertility relative to *db/db* mice (Jiang *et al.* 2008). In contrast, mice express a LepRb truncation mutant (LepRb^{Δ65}) that retains JAK2 signaling and activity but lacks Tyr₉₈₅, Tyr₁₀₇₇, and Tyr₁₁₃₈ phenocopy *db/db* animals and do not appear to be significantly protected from the obesity, diabetes and infertility that are hallmarks of impaired leptin signaling (Robertson *et al.* 2010). Thus, the improved phenotype seen in LepRb^{3F} mice relative to *db/db* animals does not result from JAK2 signaling alone, as the LepRb^{Δ65} model reveals that JAK2 signaling is not sufficient to mediate these improvements. The differing phenotypes between mice expressing LepRb^{3F} and LepRb^{Δ65} thus suggest the existence of non-canonical signaling pathway that may emanate from a distal site on LepRb, independently of LepRb pY sites. Further work will be required to identify this presumptive pathway.

While SH2B1 and IRS-protein/PI3K signaling contribute to leptin action, the mechanism(s) of their activation by LepRb remain somewhat unclear; no LepRb pY site has been definitively shown to mediate their recruitment. Thus, it is possible that one or both of these pathways constitute the presumptive LepRb pY-independent signaling pathway. Furthermore, these pathways may overlap, as SH2B1 recruits the IRS-protein/PI3K pathway during leptin signaling in cultured cells (Kim *et al.* 2000, Duan *et al.* 2004). However, the SH2B1 and IRS-protein/PI3K pathways contribute to energy balance *in vivo*. *Sh2b1*-null mice display severe early-onset obesity and hyperphagia (Ren *et al.* 2005). Furthermore, neuron-specific restoration of SH2B1 throughout the CNS rescues this phenotype, suggesting that CNS SH2B1 is crucial for the control of body weight (Morris *et al.* 2010). Unfortunately, the critical role of SH2B1 in insulin signaling (which is also significantly impacted by this deletion) as well as in signaling by other receptor tyrosine kinases renders

it challenging to determine whether this phenotype results from only from the disruption of LepRb→SH2B1 signaling.

The roles for PI3K signaling in leptin action and the control of energy balance are also complicated. Leptin administration activates IRS-protein/PI3K signaling in the mediobasal hypothalamus, and ICV treatment with PI3K inhibitors inhibits leptin's anorexigenic effects (Niswender *et al.* 2001), along with the ability of exogenous leptin to suppress *Agrp* mRNA expression in fasted rats (Morrison *et al.* 2005). Furthermore, deletion of IRS2 specifically in LepRb neurons results in obesity (although it does not impact the ability of LepRb to stimulate pSTAT3) (Sadagurski *et al.* 2012). Both *in vitro* and *in vivo* studies have also implicated PI3K signaling in the acute actions of leptin. Leptin treatment induces the depolarization of POMC neurons in slice recordings; these effects are abrogated by pretreatment with PI3K inhibitors (Hill *et al.* 2008). This effect is also perturbed in mice lacking the PI3K regulatory subunits p85 α and p85 β in POMC neurons (Hill *et al.* 2008). While these mice do not display gross phenotypic abnormalities, leptin's ability to promote acute decreases in food intake is also disrupted. Studies in which the PI3K catalytic subunits p110 α and p110 β were deleted in AgRP or POMC neurons confirm these findings – mice lacking p110 β in AgRP neurons are mildly lean, whereas mice lacking p110 β in POMC neurons are more sensitive to DIO (Al-Qassab *et al.* 2009). It is unclear however, whether these results emanate from disrupted LepRb-PI3K signaling, or from alternations in IR-PI3K signaling, especially in light of data that suggests that leptin and insulin activate non-overlapping populations of POMC neurons (Williams *et al.* 2010). Together, these data suggest that leptin-induced PI3K signaling has a limited effect on energy balance. However, the importance of the LepRb-PI3K pathway for the glucoregulatory or reproductive functions of leptin is yet to be determined.

Negative regulation of leptin signaling

Multiple pathways and proteins inhibit LepRb. Given its role as an inhibitor of LepRb signaling, the mechanisms of action for SOCS3 have been a point of considerable interest. SOCS3 binds to LepRb Tyr₉₈₅ and mediates negative feedback by directly inhibiting JAK2 activity and/or targeting the receptor-JAK2 complex for proteasomal degradation (Bjorbaek *et al.* 1998b, 1999, 2000). Neuron-wide deletion of *Socs3* using either nestin-cre (*Socs3*^{N-/-}) or synapsin-cre confers a significant resistance

to diet-induced obesity (Mori *et al.* 2004). *Socs3*^{N^{-/-}} mice also display increased leptin sensitivity as measured by both leptin-induced food intake and STAT3 phosphorylation, as well as by increased PI3K activity. While *Socs3* has not been disrupted specifically in LepRb neurons, overexpression of *Socs3* in LepRb neurons (LepRb^{Socs3-OE}) yields an unexpected phenotype of slightly increased leanness (Reed *et al.* 2010). This may result from a compensatory increase in STAT3 at baseline and a corresponding increase in pSTAT3 levels after leptin treatment, although the mechanism for this is unclear and would seem to be a bit counter-intuitive. Clearly, however, the function of SOCS3 may not be as uniform or straightforward as initially thought.

Because high-fat diet induces *Socs3* expression in the ARC, ARC populations have been posited to be a major site of leptin resistance. As a result, the role of *Socs3* in arcuate POMC and AgRP neurons has been extensively studied. As with *Socs3*^{N^{-/-}} mice, POMC^{Socs3-KO} mice are resistant to DIO, but display normal body weight on chow diet (Kievit *et al.* 2006). Interestingly, POMC^{Socs3-KO} mice also have improved glucose homeostasis on a chow diet, suggesting that POMC neurons may be a critical site of LepRb/SOCS3 signaling in the control of peripheral blood glucose levels. Unlike LepR^{Socs3-OE} mice, mice overexpressing *Socs3* in POMC neurons develop mild obesity on a chow diet, and acute leptin resistance (as assessed by leptin-induced inhibition of feeding) before any divergence in body weight (Reed *et al.* 2010). These animals also display a POMC neuron-restricted reduction in the pSTAT3 response to leptin, suggesting that potential compensatory mechanisms induced in the LepRb^{Socs3-OE} model were not activated in this more restricted cell population. AgRP^{Socs3-OE} mice also display early-onset leptin resistance, and slightly abnormal glucose homeostasis, but no alterations in body weight (Olofsson *et al.* 2013). Thus, while decreasing *Socs3* levels may prove protective against obesity, the modest body weight changes that occur with overexpression of *Socs3* suggest that increased *Socs3* levels may reflect hyperleptinemia and increased overall leptin signaling, rather than promoting obesity, *per se*.

Protein tyrosine phosphatases (PTPases) also modulate the amplitude and duration of LepRb signaling. Protein tyrosine phosphatase 1B (PTP1B) has been the most extensively studied of these, but other PTPs such as TCPTP and RPTPe also play critical roles in both leptin and insulin signaling (see review by Tsou & Bence (2013)). PTP1B is a promiscuous phosphatase that attenuates signaling by the receptor for insulin as well as other receptors, in addition to LepRb. *In vitro*, PTP1B

dose-dependently suppresses the leptin-stimulated phosphorylation of Jak2 and pSTAT3 (Zabolotny *et al.* 2002). *In vivo*, whole-body PTP1B knockout (PTP1B^{TKO}) results in a lean phenotype, resistance to DIO, and increased sensitivity to exogenous leptin, consistent with the interpretation that PTP1B is a negative regulator of LepRb signaling (Klaman *et al.* 2000). Interpretation of the PTP1B^{TKO} model is complicated by the promiscuity of PTP1B and its broad pattern of expression, however, provoking more focused studies of the sites and mechanisms of its action. Pan-neuronal deletion of PTP1B also induces a lean phenotype, whereas liver or muscle-specific deletion has no effect, and adipose-specific deletion actually causes weight gain (perhaps due to enhanced adipose insulin signaling) (Bence *et al.* 2006). LepRb neuron-specific PTP1B deletion (LepRb^{PTP1B-KO}) results in a leaner phenotype than that observed in the PTP1B^{TKO} mice, suggesting that this model may have unmasked an even more important role for PTP1B in LepRb neurons that may have been opposed by other tissue (e.g., adipose) effects in the PTP1B^{TKO} model (Tsou *et al.* 2012). The specificity of PTP1B action on LepRb for the development of the lean phenotype is supported by the similar phenotypes of hypothalamic LepRb knockout and LepRb/PTP1B double-knockout mice, suggesting the LepRb dependence of the lean phenotype of PTP1B-null animals (Tsou *et al.* 2014). Interestingly, heterozygous LepRb^{PTP1B+/-} mice display as strong a phenotype as LepRb^{PTP1B-KO}, underscoring the importance of appropriate levels of phosphatase action in the control of LepRb signaling (Tsou *et al.* 2012).

Future directions: leptin signaling and gene transcription

Despite the early identification of LepRb→STAT3 signaling as the primary mechanism for leptin's control of energy balance, LepRb→STAT3 target genes remain poorly defined. Currently, the list of genes known to be regulated by leptin *in vivo* is short: *Socs3*, *Pomc*, *Cart* (*Cartpt*), *Agrp*, and *Npy*. LepRb→STAT3 signaling is required for appropriate *Socs3*, *Pomc*, and *Agrp* gene expression, although (as noted above) *Pomc* and *Agrp* may represent indirect targets of STAT3 and/or may be partly controlled by other pathways; PI3K appears to play a role in the control of *Agrp* and *Npy* expression. Furthermore, of these five genes, only *Socs3* is thought to be induced in multiple LepRb populations; *Pomc*, *Agrp*, *Npy*, and *Cart* expression are restricted to circumscribed populations and do not contribute to leptin action in

the majority of LepRb neurons. This dearth of information about LepRb → STAT3 target genes can largely be attributed to the challenge of specifically isolating LepRb neurons from the hypothalamic milieu; LepRb neurons comprise approximately <5% of all hypothalamic neurons, making it challenging to identify cell-autonomous changes in gene transcription for any subset of neurons. Clearly, more work will be necessary to identify the hypothalamic gene targets of LepRb and STAT3 signaling. These transcripts will be responsible for much of leptin action and may represent potential targets for therapy, in addition to shedding light on the mechanisms of leptin action.

Declaration of interest

The authors declare that there is no conflict of interest that could be perceived as prejudicing the impartiality of the review.

Funding

Supported by the Michigan Diabetes Research Center (NIH Grant P30 DK020572) the NIH (DK056731, DK78056, DK098853), the American Diabetes Association, and the Marilyn H Vincent Foundation to M G M, NIH DK097861 to M B A.

References

- Ahima RS, Dushay J, Flier SN, Prabakaran D & Flier JS 1997 Leptin accelerates the onset of puberty in normal female mice. *Journal of Clinical Investigation* **99** 391–395. (doi:10.1172/JCI119172)
- Al-Qassab H, Smith MA, Irvine EE, Guillermet-Guibert J, Claret M, Choudhury AI, Selman C, Piipari K, Clements M, Lingard S *et al.* 2009 Dominant role of the p110 β isoform of PI3K over p110 α in energy homeostasis regulation by POMC and AgRP neurons. *Cell Metabolism* **10** 343–354. (doi:10.1016/j.cmet.2009.09.008)
- Banks AS, Davis SM, Bates SH & Myers MG Jr 2000 Activation of downstream signals by the long form of the leptin receptor. *Journal of Biological Chemistry* **275** 14563–14572. (doi:10.1074/jbc.275.19.14563)
- Banno R, Zimmer D, De Jonghe BC, Atienza M, Rak K, Yang W & Bence KK 2010 PTP1B and SHP2 in POMC neurons reciprocally regulate energy balance in mice. *Journal of Clinical Investigation* **120** 720–734. (doi:10.1172/JCI39620)
- Bates SH & Myers MG Jr 2003 The role of leptin receptor signaling in feeding and neuroendocrine function. *Trends in Endocrinology and Metabolism* **14** 447–452. (doi:10.1016/j.tem.2003.10.003)
- Bates SH, Stearns WH, Schubert M, Tso AW, Wang Y, Banks AS, Dundon TA, Lavery HJ, Haq AK, Maratos-Flier E *et al.* 2003 STAT3 signaling is required for leptin regulation of energy balance but not reproduction. *Nature* **421** 856–859. (doi:10.1038/nature01388)
- Bates SH, Dundon TA, Seifert M, Carlson M, Maratos-Flier E & Myers MG Jr 2004 LRB-STAT3 signaling is required for the neuroendocrine regulation of energy expenditure by leptin. *Diabetes* **53** 3067–3073. (doi:10.2337/diabetes.53.12.3067)
- Bates SH, Kulkarni RN, Seifert M & Myers MG Jr 2005 Roles for leptin receptor/STAT3-dependent and -independent signals in the regulation of glucose homeostasis. *Cell Metabolism* **1** 169–178. (doi:10.1016/j.cmet.2005.02.001)
- Baumann H, Morella KK, White DW, Dembski M, Bailon PS, Kim H, Lai CF & Tartaglia LA 1996 The full-length leptin receptor has signaling capabilities of interleukin 6-type cytokine receptors. *PNAS* **93** 8374–8378. (doi:10.1073/pnas.93.16.8374)
- Bence KK, Delibegovic M, Xue B, Gorgun CZ, Hotamisligil GS, Neel BG & Kahn BB 2006 Neuronal PTP1B regulates body weight, adiposity and leptin action. *Nature Medicine* **12** 917–924. (doi:10.1038/nm1435)
- Bjorbaek C, Elmquist JK, Michl P, Ahima RS, van Bueren A, McCall AL & Flier JS 1998a Expression of leptin receptor isoforms in rat brain microvessels. *Endocrinology* **139** 3485–3491. (doi:10.1210/endo.139.8.6154)
- Bjorbaek C, Elmquist JK, Frantz JD, Shoelson SE & Flier JS 1998b Identification of SOCS-3 as a potential mediator of central leptin resistance. *Molecular Cell* **1** 619–625. (doi:10.1016/S1097-2765(00)80062-3)
- Bjorbaek C, El Haschimi K, Frantz JD & Flier JS 1999 The role of SOCS-3 in leptin signaling and leptin resistance. *Journal of Biological Chemistry* **274** 30059–30065. (doi:10.1074/jbc.274.42.30059)
- Bjorbaek C, Lavery HJ, Bates SH, Olson RK, Davis SM, Flier JS & Myers MG Jr 2000 SOCS3 mediates feedback inhibition of the leptin receptor via Tyr985. *Journal of Biological Chemistry* **275** 40649–40657. (doi:10.1074/jbc.M007577200)
- Bjorbaek C, Buchholz RM, Davis SM, Bates SH, Pierroz DD, Gu H, Neel BG, Myers MG Jr & Flier JS 2001 Divergent roles of SHP-2 in ERK activation by leptin receptors. *Journal of Biological Chemistry* **276** 4747–4755. (doi:10.1074/jbc.M007439200)
- Bjornholm M, Munzberg H, Leshan RL, Villanueva EC, Bates SH, Louis GW, Jones JC, Ishida-Takahashi R, Bjorbaek C & Myers MG Jr 2007 Mice lacking inhibitory leptin receptor signals are lean with normal endocrine function. *Journal of Clinical Investigation* **117** 1354–1360. (doi:10.1172/JCI30688)
- Chen H, Charlat O, Tartaglia LA, Woolf EA, Weng X, Ellis SJ, Lakey ND, Culpepper J, Moore KJ, Breitbart RE *et al.* 1996 Evidence that the diabetes gene encodes the leptin receptor: identification of a mutation in the leptin receptor gene in db/db mice. *Cell* **84** 491–495. (doi:10.1016/S0092-8674(00)81294-5)
- Chua SC Jr, Chung WK, Wu-Peng XS, Zhang Y, Liu SM, Tartaglia L & Leibel RL 1996 Phenotypes of mouse diabetes and rat fatty due to mutations in the OB (leptin) receptor. *Science* **271** 994–996. (doi:10.1126/science.271.5251.994)
- Chua SC Jr, Koutras IK, Han L, Liu SM, Kay J, Young SJ, Chung WK & Leibel RL 1997 Fine structure of the murine leptin receptor gene: splice site suppression is required to form two alternatively spliced transcripts. *Genomics* **45** 264–270. (doi:10.1006/geno.1997.4962)
- Danaei G, Finucane MM, Lu Y, Singh GM, Cowan MJ, Paciorek CJ, Lin JK, Farzadfar F, Khang YH, Stevens GA *et al.* 2011 National, regional, and global trends in fasting plasma glucose and diabetes prevalence since 1980: systematic analysis of health examination surveys and epidemiological studies with 370 country-years and 2.7 million participants. *Lancet* **378** 31–40. (doi:10.1016/S0140-6736(11)60679-X)
- Devos R, Guise Y, Van der Heyden J, White DW, Kalai M, Fountoulakis M & Plaetinck G 1997 Ligand-independent dimerization of the extracellular domain of the leptin receptor and determination of the stoichiometry of leptin binding. *Journal of Biological Chemistry* **272** 18304–18310. (doi:10.1074/jbc.272.29.18304)
- Duan C, Li M & Rui L 2004 SH2-B promotes insulin receptor substrate 1 (IRS1)- and IRS2-mediated activation of the phosphatidylinositol 3-kinase pathway in response to leptin. *Journal of Biological Chemistry* **279** 43684–43691. (doi:10.1074/jbc.M408495200)
- Elias CF, Kelly JF, Lee CE, Ahima RS, Drucker DJ, Saper CB & Elmquist JK 2000 Chemical characterization of leptin-activated neurons in the rat brain. *Journal of Comparative Neurology* **423** 261–281. (doi:10.1002/1096-9861(20000724)423:2%3C;261::AID-CNE6%3E;3.0.CO;2-6)
- Elmquist JK, Coppari R, Balthasar N, Ichinose M & Lowell BB 2005 Identifying hypothalamic pathways controlling food intake,

- body weight, and glucose homeostasis. *Journal of Comparative Neurology* **493** 63–71. (doi:10.1002/cne.20786)
- Ernst MB, Wunderlich CM, Hess S, Paehler M, Mesaros A, Korolov SB, Kleinriders A, Husch A, Munzberg H, Hampel B *et al.* 2009 Enhanced Stat3 activation in POMC neurons provokes negative feedback inhibition of leptin and insulin signaling in obesity. *Journal of Neuroscience* **29** 11582–11593. (doi:10.1523/JNEUROSCI.5712-08.2009)
- Farooqi IS, Jebb SA, Langmack G, Lawrence E, Cheetham CH, Prentice AM, Hughes IA, McCamish MA & O'Rahilly S 1999 Effects of recombinant leptin therapy in a child with congenital leptin deficiency. *New England Journal of Medicine* **341** 879–884. (doi:10.1056/NEJM199909163411204)
- Farooqi IS, Matarese G, Lord GM, Keogh JM, Lawrence E, Agwu C, Sanna V, Jebb SA, Perna F, Fontana S *et al.* 2002 Beneficial effects of leptin on obesity, T cell hyporesponsiveness, and neuroendocrine/metabolic dysfunction of human congenital leptin deficiency. *Journal of Clinical Investigation* **110** 1093–1103. (doi:10.1172/JCI0215693)
- Frederich RC, Hamann A, Anderson S, Lollmann B, Lowell BB & Flier JS 1995a Leptin levels reflect body lipid content in mice: evidence for diet-induced resistance to leptin action. *Nature Medicine* **1** 1311–1314. (doi:10.1038/nm1295-1311)
- Frederich RC, Lollmann B, Hamann A, Napolitano-Rosen A, Kahn BB, Lowell BB & Flier JS 1995b Expression of ob mRNA and its encoded protein in rodents: impact of nutrition and obesity. *Journal of Clinical Investigation* **96** 1658–1663. (doi:10.1172/JCI118206)
- Friedman JM & Halaas JL 1998 Leptin and the regulation of body weight in mammals. *Nature* **395** 763–770. (doi:10.1038/27376)
- Gao Q, Wolfgang MJ, Neschen S, Morino K, Horvath TL, Shulman GI & Fu XY 2004 Disruption of neural signal transducer and activator of transcription 3 causes obesity, diabetes, infertility, and thermal dysregulation. *PNAS* **101** 4661–4666. (doi:10.1073/pnas.0303992101)
- Gong Y, Ishida-Takahashi R, Villanueva EC, Fingar DC, Munzberg H & Myers MG Jr 2007 The long form of the leptin receptor regulates STAT5 and ribosomal protein S6 via alternate mechanisms. *Journal of Biological Chemistry* **282** 31019–31027. (doi:10.1074/jbc.M702838200)
- Gong L, Yao F, Hockman K, Heng HH, Morton GJ, Takeda K, Akira S, Low MJ, Rubinstein M & MacKenzie RG 2008 Signal transducer and activator of transcription-3 is required in hypothalamic agouti-related protein/neuropeptide Y neurons for normal energy homeostasis. *Endocrinology* **149** 3346–3354. (doi:10.1210/en.2007-0945)
- Hall ME, Smith G, Hall JE & Stec DE 2011 Systolic dysfunction in cardiac-specific ligand-inducible MerCreMer transgenic mice. *American Journal of Physiology. Heart and Circulatory Physiology* **301** H253–H260. (doi:10.1152/ajpheart.00786.2010)
- Hall ME, Smith G, Hall JE & Stec DE 2012 Cardiomyocyte-specific deletion of leptin receptors causes lethal heart failure in Cre-recombinase-mediated cardiotoxicity. *American Journal of Physiology. Regulatory, Integrative and Comparative Physiology* **303** R1241–R1250. (doi:10.1152/ajpregu.00292.2012)
- Hayes MR, Skibicka KP, Lechner TM, Guarnieri DJ, DiLeone RJ, Bence KK & Grill HJ 2010 Endogenous leptin signaling in the caudal nucleus tractus solitarius and area postrema is required for energy balance regulation. *Cell Metabolism* **11** 77–83. (doi:10.1016/j.cmet.2009.10.009)
- He Z, Zhang SS, Meng Q, Li S, Zhu HH, Raquil MA, Alderson N, Zhang H, Wu J, Rui L *et al.* 2012 Shp2 controls female body weight and energy balance by integrating leptin and estrogen signals. *Molecular and Cellular Biology* **32** 1867–1878. (doi:10.1128/MCB.06712-11)
- Hill JW, Williams KW, Ye C, Luo J, Balthasar N, Coppari R, Cowley MA, Cantley LC, Lowell BB & Elmquist JK 2008 Acute effects of leptin require PI3K signaling in hypothalamic proopiomelanocortin neurons in mice. *Journal of Clinical Investigation* **118** 1796–1805. (doi:10.1172/JCI32964)
- Hommel JD, Trinko R, Sears RM, Georgescu D, Liu ZW, Gao XB, Thurmon JJ, Marinelli M & DiLeone RJ 2006 Leptin receptor signaling in midbrain dopamine neurons regulates feeding. *Neuron* **51** 801–810. (doi:10.1016/j.neuron.2006.08.023)
- Huynh FK, Levi J, Denroche HC, Gray SL, Voshol PJ, Neumann UH, Speck M, Chua SC, Covey SD & Kieffer TJ 2010 Disruption of hepatic leptin signaling protects mice from age- and diet-related glucose intolerance. *Diabetes* **59** 3032–3040. (doi:10.2337/db10-0074)
- Jiang L, You J, Yu X, Gonzalez L, Yu Y, Wang Q, Yang G, Li W, Li C & Liu Y 2008 Tyrosine-dependent and -independent actions of leptin receptor in control of energy balance and glucose homeostasis. *PNAS* **105** 18619–18624. (doi:10.1073/pnas.0804589105)
- Kastin AJ, Pan W, Maness LM, Koletsky RJ & Ernberger P 1999 Decreased transport of leptin across the blood–brain barrier in rats lacking the short form of the leptin receptor. *Peptides* **20** 1449–1453. (doi:10.1016/S0196-9781(99)00156-4)
- Kievit P, Howard JK, Balthasar N, Coppari R, Mori H, Lee CE, Elmquist JK, Yoshimura A & Flier JS 2006 Enhanced leptin sensitivity and improved glucose homeostasis in mice lacking suppressor of cytokine signaling-3 in POMC-expressing cells. *Cell Metabolism* **4** 123–132. (doi:10.1016/j.cmet.2006.06.010)
- Kim YB, Uotani S, Pierroz DD, Flier JS & Kahn BB 2000 *In vivo* administration of leptin activates signal transduction directly in insulin-sensitive tissues: overlapping but distinct pathways from insulin. *Endocrinology* **141** 2328–2339.
- Kim MS, Pak YK, Jang PG, Namkoong C, Choi YS, Won JC, Kim KS, Kim SW, Kim HS, Park JY *et al.* 2006 Role of hypothalamic Foxo1 in the regulation of food intake and energy homeostasis. *Nature Neuroscience* **9** 901–906. (doi:10.1038/nn1731)
- Kitamura T, Feng Y, Ido KY, Chua SC, Xu AW, Barsh GS, Rossetti L & Accili D 2006 Forkhead protein FoxO1 mediates Agrp-dependent effects of leptin on food intake. *Nature Medicine* **12** 534–540. (doi:10.1038/nm1392)
- Klaman LD, Boss O, Peroni OD, Kim JK, Martino JL, Zabolotny JM, Moghal N, Lubkin M, Kim YB, Sharpe AH *et al.* 2000 Increased energy expenditure, decreased adiposity, and tissue-specific insulin sensitivity in protein-tyrosine phosphatase 1B-deficient mice. *Molecular and Cellular Biology* **20** 5479–5489. (doi:10.1128/MCB.20.15.5479-5489.2000)
- Kloek C, Haq AK, Dunn SL, Lavery HJ, Banks AS & Myers MG Jr 2002 Regulation of Jak kinases by intracellular leptin receptor sequences. *Journal of Biological Chemistry* **277** 41547–41555. (doi:10.1074/jbc.M205148200)
- Lee GH, Proenca R, Montez JM, Carroll KM, Darvishzadeh JG, Lee JI & Friedman JM 1996 Abnormal splicing of the leptin receptor in diabetic mice. *Nature* **379** 632–635. (doi:10.1038/379632a0)
- Lee JY, Muenzberg H, Gavrilova O, Reed JA, Berryman D, Villanueva EC, Louis GW, Leininger GM, Bertuzzi S, Seeley RJ *et al.* 2008 Loss of cytokine-STAT5 signaling in the CNS and pituitary gland alters energy balance and leads to obesity. *PLoS ONE* **3** e1639. (doi:10.1371/journal.pone.0001639)
- Liu J, Garza JC, Bronner J, Kim CS, Zhang W & Lu XY 2010 Acute administration of leptin produces anxiolytic-like effects: a comparison with fluoxetine. *Psychopharmacology* **207** 535–545. (doi:10.1007/s00213-009-1684-3)
- Liu J, Perez SM, Zhang W, Lodge DJ & Lu XY 2011 Selective deletion of the leptin receptor in dopamine neurons produces anxiogenic-like behavior and increases dopaminergic activity in amygdala. *Molecular Psychiatry* **16** 1024–1038. (doi:10.1038/mp.2011.36)
- Lu XY, Kim CS, Frazer A & Zhang W 2006 Leptin: a potential novel antidepressant. *PNAS* **103** 1593–1598. (doi:10.1073/pnas.0508901103)
- Maffei M, Halaas J, Ravussin E, Pratley RE, Lee GH, Zhang Y, Fei H, Kim S, Lallone R, Ranganathan S *et al.* 1995 Leptin levels in human and rodent: measurement of plasma leptin and ob RNA in obese and

- weight-reduced subjects. *Nature Medicine* **1** 1155–1161. (doi:10.1038/nm1195-1155)
- Mesáros A, Koralov SB, Rother E, Wunderlich FT, Ernst MB, Barsh GS, Rajewsky K & Bruning JC 2008 Activation of Stat3 signaling in AgRP neurons promotes locomotor activity. *Cell Metabolism* **7** 236–248. (doi:10.1016/j.cmet.2008.01.007)
- Montague CT, Farooqi IS, Whitehead JP, Soos MS, Rau H, Wareham NJ, Sewter CP, Digby JE, Mohammed SN, Hurst JA *et al.* 1997 Congenital leptin deficiency is associated with severe early onset obesity in humans. *Nature* **387** 903–908. (doi:10.1038/43185)
- Mori H, Hanada R, Hanada T, Aki D, Mashima R, Nishinakamura H, Torisu T, Chien KR, Yasukawa H & Yoshimura A 2004 Socs3 deficiency in the brain elevates leptin sensitivity and confers resistance to diet-induced obesity. *Nature Medicine* **10** 739–743. (doi:10.1038/nm1071)
- Morioka T, Asilmaz E, Hu J, Dishinger JF, Kurpad AJ, Elias CF, Li H, Elmquist JK, Kennedy RT & Kulkarni RN 2007 Disruption of leptin receptor expression in the pancreas directly affects β cell growth and function in mice. *Journal of Clinical Investigation* **117** 2860–2868. (doi:10.1172/JCI30910)
- Morris DL, Cho KW & Rui L 2010 Critical role of the Src homology 2 (SH2) domain of neuronal SH2B1 in the regulation of body weight and glucose homeostasis in mice. *Endocrinology* **151** 3643–3651. (doi:10.1210/en.2010-0254)
- Morrison CD, Morton GJ, Niswender KD, Gelling RW & Schwartz MW 2005 Leptin inhibits hypothalamic Npy and AgRP gene expression via a mechanism that requires phosphatidylinositol 3-OH-kinase signaling. *American Journal of Physiology. Endocrinology and Metabolism* **289** E1051–E1057. (doi:10.1152/ajpendo.00094.2005)
- Munzberg H, Huo L, Nillni EA, Hollenberg AN & Bjorbaek C 2003 Role of signal transducer and activator of transcription 3 in regulation of hypothalamic proopiomelanocortin gene expression by leptin. *Endocrinology* **144** 2121–2131. (doi:10.1210/en.2002-221037)
- Myers MG Jr, Munzberg H, Leininger GM & Leshan RL 2009 The geometry of leptin action in the brain: more complicated than a simple ARC. *Cell Metabolism* **9** 117–123. (doi:10.1016/j.cmet.2008.12.001)
- Niswender KD, Morton GJ, Stearns WH, Rhodes CJ, Myers MG Jr & Schwartz MW 2001 Intracellular signalling key enzyme in leptin-induced anorexia. *Nature* **413** 794–795. (doi:10.1038/35101657)
- Olofsson LE, Unger EK, Cheung CC & Xu AW 2013 Modulation of AgRP-neuronal function by SOCS3 as an initiating event in diet-induced hypothalamic leptin resistance. *PNAS* **110** E697–E706. (doi:10.1073/pnas.1218284110)
- Patterson CM, Leshan RL, Jones JC & Myers MG Jr 2011 Molecular mapping of mouse brain regions innervated by leptin receptor-expressing cells. *Brain Research* **1378** 18–28. (doi:10.1016/j.brainres.2011.01.010)
- Patterson CM, Villanueva EC, Greenwald-Yarnell M, Rajala M, Gonzalez IE, Saini N, Jones J & Myers MG Jr 2012 Leptin action via LepR-b Tyr1077 contributes to the control of energy balance and female reproduction. *Molecular Metabolism* **1** 61–69. (doi:10.1016/j.molmet.2012.05.001)
- Piper ML, Unger EK, Myers MG Jr & Xu AW 2007 Specific physiological roles for Stat3 in leptin receptor-expressing neurons. *Molecular Endocrinology* **22** 751–759. (doi:10.1210/me.2007-0389)
- Rajala MW, Patterson CM, Opp JS, Foltin SK, Young VB & Myers MG Jr 2014 Leptin acts independently of food intake to modulate gut microbial composition in male mice. *Endocrinology* **155** 748–757. (doi:10.1210/en.2013-1085)
- Reed AS, Unger EK, Olofsson LE, Piper ML, Myers MG Jr & Xu AW 2010 Functional role of suppressor of cytokine signaling 3 upregulation in hypothalamic leptin resistance and long-term energy homeostasis. *Diabetes* **59** 894–906. (doi:10.2337/db09-1024)
- Ren D, Li M, Duan C & Rui L 2005 Identification of SH2-B as a key regulator of leptin sensitivity, energy balance, and body weight in mice. *Cell Metabolism* **2** 95–104. (doi:10.1016/j.cmet.2005.07.004)
- Ring LE & Zeltser LM 2010 Disruption of hypothalamic leptin signaling in mice leads to early-onset obesity, but physiological adaptations in mature animals stabilize adiposity levels. *Journal of Clinical Investigation* **120** 2931–2941. (doi:10.1172/JCI41985)
- Robertson S, Ishida-Takahashi R, Tawara I, Hu J, Patterson CM, Jones JC, Kulkarni RN & Myers MG Jr 2010 Insufficiency of Janus kinase 2-autonomous leptin receptor signals for most physiologic leptin actions. *Diabetes* **59** 782–790. (doi:10.2337/db09-1556)
- Sadagurski M, Leshan RL, Patterson C, Rozzo A, Kuznetsova A, Skorupski J, Jones JC, Depinho RA, Myers MG Jr & White MF 2012 IRS2 signaling in LepR-b neurons suppresses FoxO1 to control energy balance independently of leptin action. *Cell Metabolism* **15** 703–712. (doi:10.1016/j.cmet.2012.04.011)
- Schwartz MW, Woods SC, Porte D Jr, Seeley RJ & Baskin DG 2000 Central nervous system control of food intake. *Nature* **404** 661–671.
- Schwartz MW, Guyenet SJ & Cirulli V 2010 The hypothalamus and ss-cell connection in the gene-targeting era. *Diabetes* **59** 2991–2993. (doi:10.2337/db10-1149)
- Scott MM, Lachey JL, Sternson SM, Lee CE, Elias CF, Friedman JM & Elmquist JK 2009 Leptin targets in the mouse brain. *Journal of Comparative Neurology* **514** 518–532. (doi:10.1002/cne.22025)
- Shpilman M, Niv-Spector L, Katz M, Varol C, Solomon G, Ayalon-Soffer M, Boder E, Halpern Z, Elinav E & Gertler A 2011 Development and characterization of high affinity leptins and leptin antagonists. *Journal of Biological Chemistry* **286** 4429–4442. (doi:10.1074/jbc.M110.196402)
- Singireddy AV, Inglis MA, Zuure WA, Kim JS & Anderson GM 2013 Neither signal transducer and activator of transcription 3 (STAT3) or STAT5 signaling pathways are required for leptin's effects on fertility in mice. *Endocrinology* **154** 2434–2445. (doi:10.1210/en.2013-1109)
- Tartaglia LA 1997 The leptin receptor. *Journal of Biological Chemistry* **272** 6093–6096. (doi:10.1074/jbc.272.10.6093)
- Tartaglia LA, Dembski M, Weng X, Deng N, Culpepper J, Devos R, Richards GJ, Campfield LA, Clark FT, Deeds J *et al.* 1995 Identification and expression cloning of a leptin receptor, OB-R. *Cell* **83** 1263–1271. (doi:10.1016/0092-8674(95)90151-5)
- Tobe K, Ogura T, Tsukamoto C, Imai A, Matsuura K, Iwasaki Y, Shimomura H, Higashi T & Tsuji T 1999 Relationship between serum leptin and fatty liver in Japanese male adolescent university students. *American Journal of Gastroenterology* **94** 3328–3335. (doi:10.1111/j.1572-0241.1999.01549.x)
- Tsou RC & Bence KK 2013 Central regulation of metabolism by protein tyrosine phosphatases. *Frontiers in Neuroscience* **6** 192. (doi:10.3389/fnins.2012.00192)
- Tsou RC, Zimmer DJ, De Jonghe BC & Bence KK 2012 Deficiency of PTP1B in leptin receptor-expressing neurons leads to decreased body weight and adiposity in mice. *Endocrinology* **153** 4227–4237. (doi:10.1210/en.2012-1548)
- Tsou RC, Rak KS, Zimmer DJ & Bence KK 2014 Improved metabolic phenotype of hypothalamic PTP1B-deficiency is dependent upon the leptin receptor. *Molecular Metabolism* **3** 301–312. (doi:10.1016/j.molmet.2014.01.008)
- White DW, Kuropatwinski KK, Devos R, Baumann H & Tartaglia LA 1997 Leptin receptor (OB-R) signaling. Cytoplasmic domain mutational analysis and evidence for receptor homo-oligomerization. *Journal of Biological Chemistry* **272** 4065–4071. (doi:10.1074/jbc.272.7.4065)
- Wicksteed B, Brissova M, Yan W, Opland DM, Plank JL, Reinert RB, Dickson LM, Tamarina NA, Philipson LH, Shostak A *et al.* 2010 Conditional gene targeting in mouse pancreatic α -cells: analysis of ectopic Cre transgene expression in the brain. *Diabetes* **59** 3090–3098. (doi:10.2337/db10-0624)
- Williams KW, Margatho LO, Lee CE, Choi M, Lee S, Scott MM, Elias CF & Elmquist JK 2010 Segregation of acute leptin and insulin effects in distinct populations of arcuate proopiomelanocortin neurons.

- Journal of Neuroscience* **30** 2472–2479. (doi:10.1523/JNEUROSCI.3118-09.2010)
- Xu AW, Ste-Marie L, Kaelin CB & Barsh GS 2007 Inactivation of signal transducer and activator of transcription 3 in proopiomelanocortin (Pomc) neurons causes decreased pomc expression, mild obesity, and defects in compensatory refeeding. *Endocrinology* **148** 72–80. (doi:10.1210/en.2006-1119)
- Yang G, Ge H, Boucher A, Yu X & Li C 2004 Modulation of direct leptin signaling by soluble leptin receptor. *Molecular Endocrinology* **18** 1354–1362. (doi:10.1210/me.2004-0027)
- Zabolotny JM, Bence-Hanulec KK, Stricker-Krongrad A, Haj F, Wang Y, Minokoshi Y, Kim YB, Elmquist JK, Tartaglia LA, Kahn BB *et al.* 2002 PTP1B regulates leptin signal transduction *in vivo*. *Developmental Cell* **2** 489–495. (doi:10.1016/S1534-5807(02)00148-X)
- Zastrow O, Seidel B, Kiess W, Thiery J, Keller E, Bottner A & Kratzsch J 2003 The soluble leptin receptor is crucial for leptin action: evidence from clinical and experimental data. *International Journal of Obesity and Related Metabolic Disorders* **27** 1472–1478. (doi:10.1038/sj.ijo.0802432)
- Zhang J & Scarpace PJ 2009 The soluble leptin receptor neutralizes leptin-mediated STAT3 signalling and anorexic responses *in vivo*. *British Journal of Pharmacology* **158** 475–482. (doi:10.1111/j.1476-5381.2009.00246.x)
- Zhang Y, Proenca R, Maffei M, Barone M, Leopold L & Friedman JM 1994 Positional cloning of the mouse obese gene and its human homologue. *Nature* **372** 425–432. (doi:10.1038/372425a0)
- Zhang EE, Chapeau E, Hagihara K & Feng GS 2004 Neuronal Shp2 tyrosine phosphatase controls energy balance and metabolism. *PNAS* **101** 16064–16069. (doi:10.1073/pnas.0405041101)

Received in final form 5 August 2014

Accepted 8 August 2014